

MEMSENSE

H3-IMU

PRELIMINARY

High Performance Inertial Measurement Unit

PRELIMINARY

FUNCTIONAL DESCRIPTION

The H3-IMU provides serial digital outputs of triaxial acceleration, rate of turn (gyro) and magnetic field data. Custom algorithms provide high performance, temperature compensated data in real time via the RS-422 protocol at sample rates up to 1000 Hz. Two performance options are available the HN for normal applications or the HP which dramatically reduces the accelerometer bias offset and noise. The H3-IMU also supports 2 spare analog inputs, 3 spare digital inputs and 2 spare digital outputs. The H3 is available in a custom package measuring 2.000 in. x 1.110 in. x 0.645 in. height. The H3-IMU is provided with a 15 pin Bi-Lobe connector. Table 2 details the pin-out of the connector configuration.

For pricing information contact MEMSense Sales at 888.668.8743, Extension Number 15, or via email at sales@memsense.com.

APPLICATIONS

- Unmanned Aerial Vehicles
- Unmanned Underwater Vehicles
- Missile Correction
- Antenna Control/Stabilization
- Turret Control/Stabilization
- Sports Performance Analysis

FEATURES

- Sample rates up to 1000 Hz
- Accelerometer Dynamic Ranges: $\pm 2g$ to $\pm 200g$
- 1 Sigma accelerometer bias repeatability: 1.5 mg
- Angular Rates: ± 50 °/s to ± 5400 °/s
- Gyro Bias Instability: 20 °/h
- Gyro Angle Random Walk: 2 °/h^{1/2}
- Magnetometer Dynamic Range: ± 1.9 gauss
- Corrected for Bias, Scale Factor and Cross Sensitivity
- Physical Dimensions: 2.000 x 1.110 x 0.645 inches
- Mass < 50 grams.

ORDERING INFORMATION

Table 1 – Standard Part Numbers

Part Number	Accel (g)	Rate (°/s)	Bandwidth (Hz)	Protocol
HN02-0150F050R	2	150	50	RS422
HP02-0150F050R	2	150	50	RS422
HN02-0300F050R	2	300	50	RS422
HP02-0300F050R	2	300	50	RS422
HN05-0300F050R	5	300	50	RS422
HP05-0300F050R	5	300	50	RS422
HN05-0600F050R	5	600	50	RS422
HP05-0600F050R	5	600	50	RS422
HN10-1200F050R	10	1200	50	RS422
HP10-1200F050R	10	1200	50	RS422

ORIENTATION DIAGRAM



Figure 1 – H3-IMU

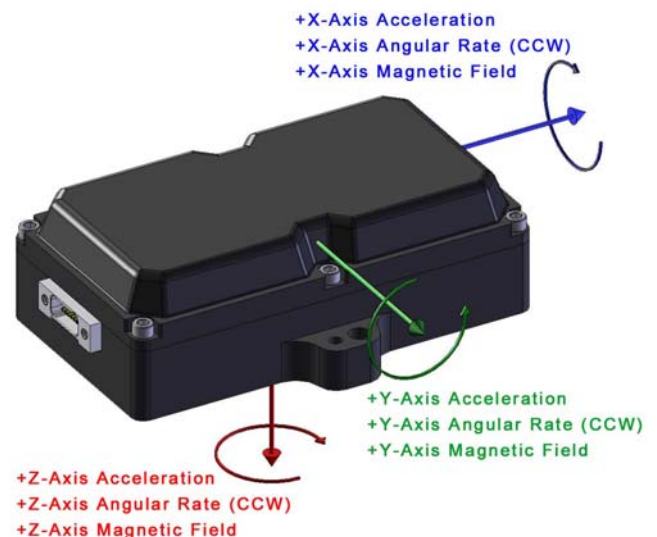

Figure 2 – H3-IMU Orientation Diagram

SPECIFICATIONS

Table 2 – Specifications

PARAMETER	SPECIFICATION				UNITS	CONDITIONS
Operational Requirements						
Supply Voltage	5.4 to 9.0				VDC	Typical
Supply Current	300				mA	
Physical Properties						
Alignment Error	±1				%	
Mass	45				grams	
Acceleration – HN Option	HN02	HN05	HN10			
Dynamic Range	± 2	± 5	± 10	g	0 to 70 °C Maximum Typical (Maximum) Typical (Maximum), 1 σ -3dB point	
Offset	± 30	± 30	± 30	mg		
Nonlinearity	± 0.4 (± 1.0)	± 0.4 (± 1.0)	± 0.4 (± 1.0)	% of FS		
Noise	0.6 (0.8)	1.1 (1.3)	2.1 (2.8)	mg		
Digital Scale Factor	9.1553E-05	2.2888E-04	4.5776E-04	g/bit		
Bandwidth ¹	50	50	50	Hz		
Acceleration – HP Option	HP02	HP05	HP10			
Dynamic Range	± 2	± 5	± 10	g	0 to 70 °C Maximum Typical (Maximum) Typical (Maximum), 1 σ -3dB point	
Offset	± 2.25	± 5.63	± 11.25	mg		
Nonlinearity	± 0.3 (± 0.8)	± 0.3 (± 0.8)	± 0.3 (± 0.8)	% of FS		
Noise	0.127 (0.170)	0.127 (0.170)	0.127 (0.170)	mg		
Digital Scale Factor	9.1553E-05	2.2888E-04	4.5776E-04	g/bit		
Bandwidth ¹	50	50	50	Hz		
Angular Rate	-0150F050	-0300F050	-0600F050	-1200F050		
Dynamic Range	± 150	± 300	± 600	± 1200	°/s	0 to 70 °C Maximum Maximum Best fit straight line Typical (Maximum), 1 σ -3dB point
Offset	+/-1.5	+/-1.5	+/-1.5	+/-1.5	°/s	
Cross-Axis Sensitivity	+/-1	+/-1	+/-1	+/-1	%	
Nonlinearity	0.1	0.1	0.1	0.1	% of FS	
Noise	0.36 (0.95)	0.56 (0.95)	0.56 (0.95)	0.56 (0.95)	°/s	
Digital Scale Factor	6.8665E-03	1.3733E-02	2.7466E-02	5.4932E-02	°/s/bit	
Bandwidth ¹	50	50	50	50	Hz	
Magnetic Field						
Dynamic Range	±1.9				gauss	Maximum Best fit straight line Typical (Maximum), 1 σ -3dB point
Offset	0.020				gauss	
Nonlinearity	0.5				% of FS	
Noise	0.00056 (0.0015)				gauss	
Digital Scale Factor	8.6975E-05				gauss/bit	
Bandwidth ¹	50				Hz	
Temperature						
Digital Sensitivity	1.8165E-02				°C/bit	
External Analog Inputs						
Voltage Range	0 to 5				VDC	-3dB point
Input Impedance	8				MΩ	
Bandwidth	482				Hz	
External Digital Inputs	Minimum		Maximum			
High Level Input Voltage	2.31		3.3		V	
Low Level Input Voltage	0		0.99		V	
Input Leakage Current	± 1				μA	
Absolute Max Ratings						
Acceleration Powered	2000 max				g	Any axis 0.5ms
Supply Voltage	-0.3 (min) +12 (max)				VDC	
Operating Temperature	0 to +70				°C	
Storage Temperature	-55 to +125				°C	

Typical Values at 25°C, Supply Voltage = 5.6 VDC, 0 °/s, unless otherwise noted.

- 1.) Other bandwidth configurations are available upon request.
- 2.) Other configurations are available on a special order basis. Contact sales for more information.

MEMSENSE

H3-IMU

PRELIMINARY

High Performance Inertial Measurement Unit

PRELIMINARY

FUNCTIONAL BLOCK DIAGRAM

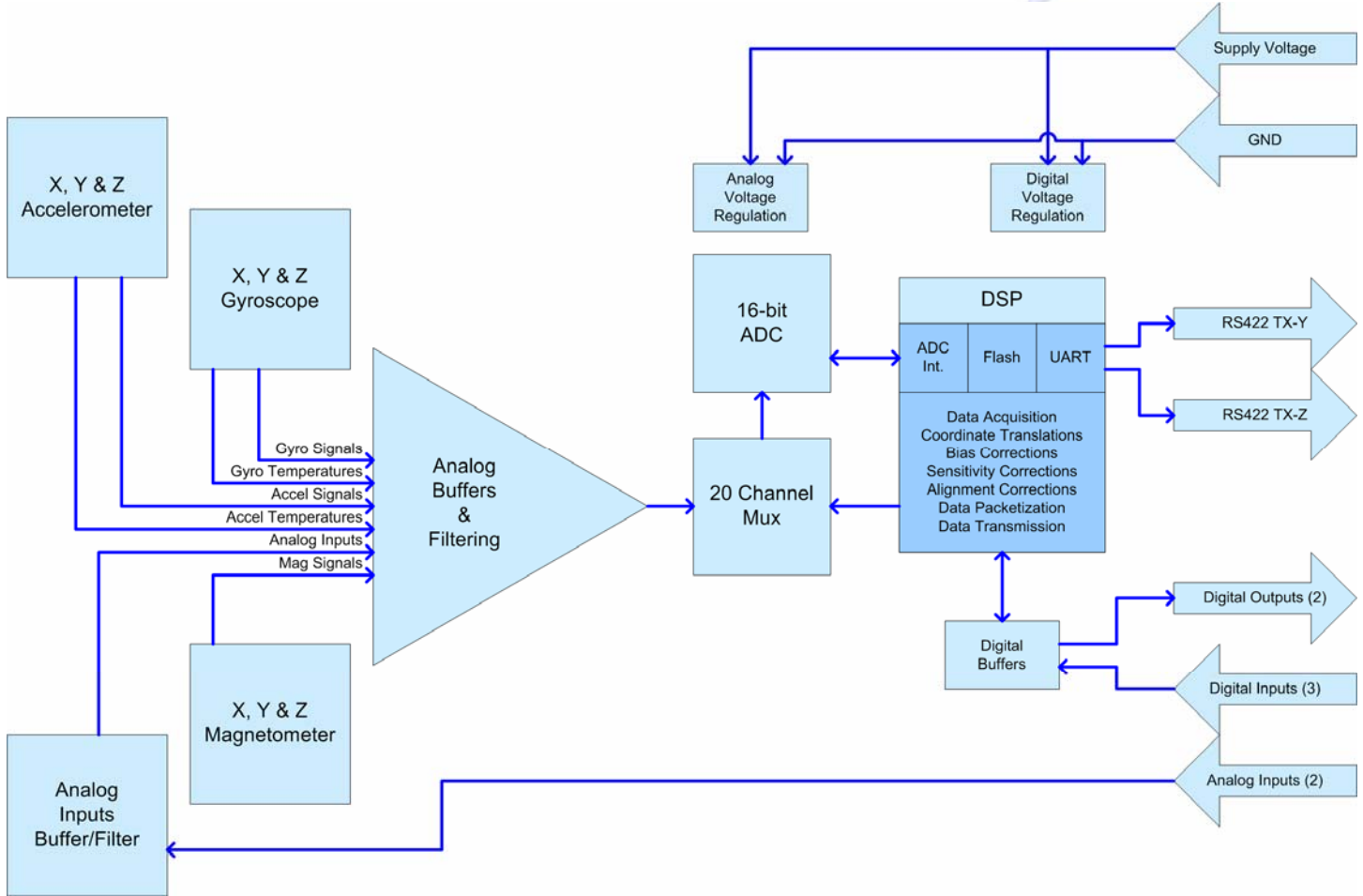

Figure 3 – H3-IMU Functional Block Diagram

PIN FUNCTION DESCRIPTIONS

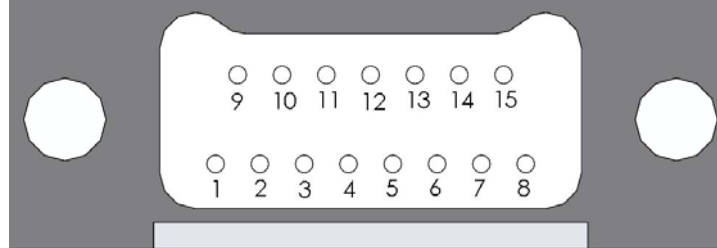

Figure 4 – Omnetics Bi-Lobe Nano interface connector A29100-015

Table 3 – H3-IMU Connector Interface Pin Functions

Pin No.	Signal Name	Description	Wire Color
1	VSUPPLY	Supply Voltage Input	Black 1
2	GND	Supply Voltage Return	Brown 1
3	ASPIN2	Analog External Input 2	Red 1
4	DSPIN2	Digital External Input 2 (Not Implemented in Revision A)	Orange 1
5	DSPOUT1	Digital Sensor Encode Pulse Output	Yellow 1
6	DSPOUT2	Pulse Output at 1 Second Intervals	Green 1
7	TX_Z	RS422 Inverting Output	Blue 1
8	TX_Y	RS422 Non-Inverting Output	Purple 1
9	GND	Supply Voltage Return	Grey 1
10	ASPIN1	Analog External Input 1	White 1
11	DSPIN1	Digital External Input 1 (Not Implemented in Revision A)	Black 2
12	DSPIN3	Digital External Input 3 (Not Implemented in Revision A)	Brown 2
13	NC	No Connect, Internal Use Only	Red 2
14	RX_B	RS422 Inverting Input (Not Implemented in Revision A)	Orange 2
15	RX_A	RS422 Non-Inverting Input (Not Implemented in Revision A)	Yellow 2

Note: Mating connector is from Omnetics part number A28000-015 (included with your order).

MEMSENSE

H3-IMU

PRELIMINARY

High Performance Inertial Measurement Unit

PRELIMINARY

USB Data Acquisition (DAQ) Module Options

Every H3-IMU ordered comes standard with a USB Data Acquisition DAQ Module that is powered via USB. No external power supply is required. A USB DAQ with leads to connect to an external power supply is also available; if this is your preference please let sales know when you place your order and they will substitute the externally power powered USB DAQ for no additional charge.

Table 5 – USB DAQ Module Options

Model Number	Description	Max Voltage	Power Source	Protocol	Availability
USB-H-8.5UR	H3-IMU USB RS422 DAQ, USB power	8.5V	USB	RS422	Standard – with all H3-IMUs ordered
USB-H-8.5XR	H3-IMU USB RS422 DAQ, Ext. power	8.5V	External Power	RS422	Option available upon request

PHYSICAL DIMENSIONS

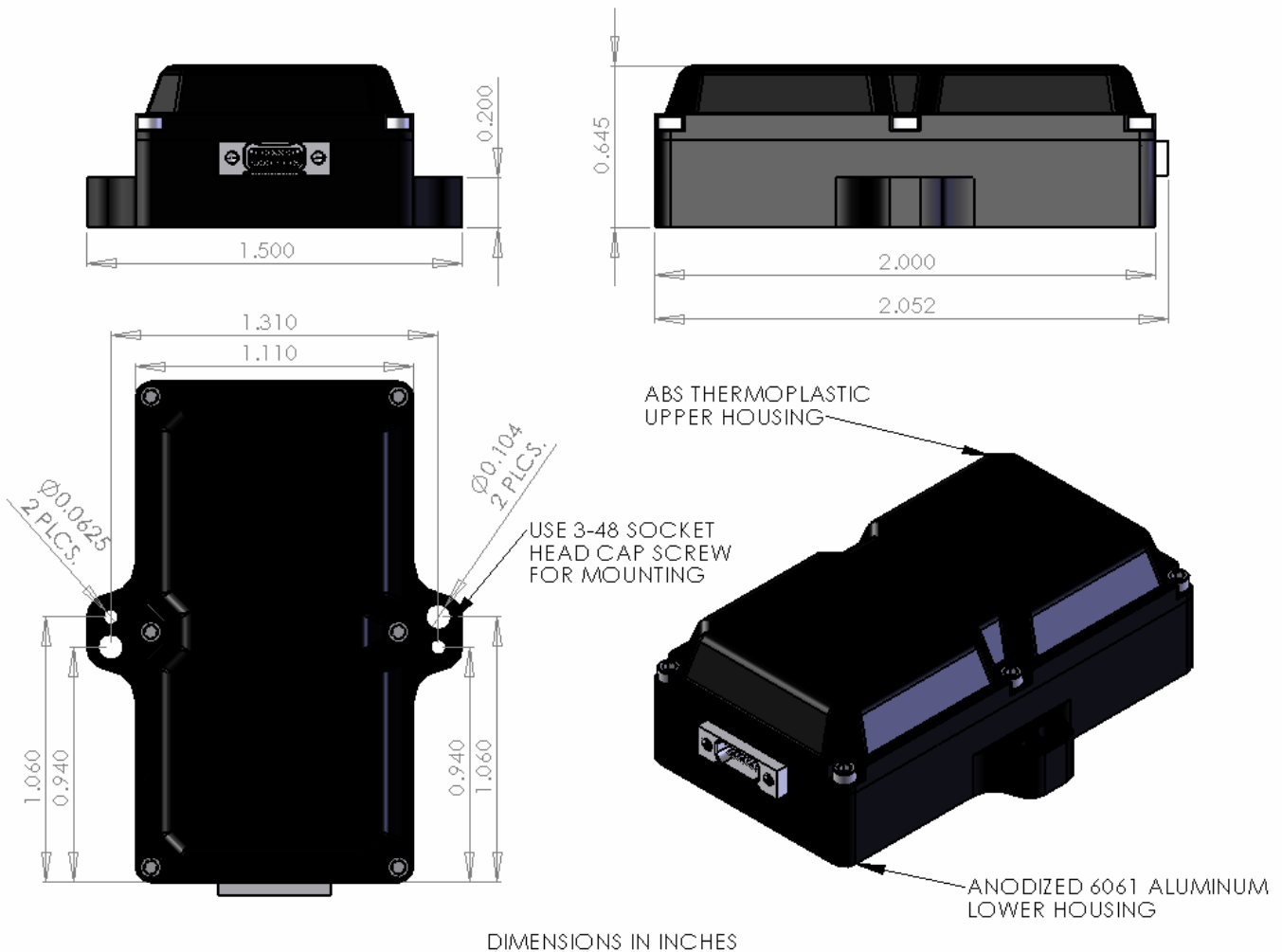

Figure 5 – Physical Dimensions

Document Change History

Rev	Status	Description	Date
A	Preliminary	New Data Sheet	5/XX/2010