

# MEMSENSE

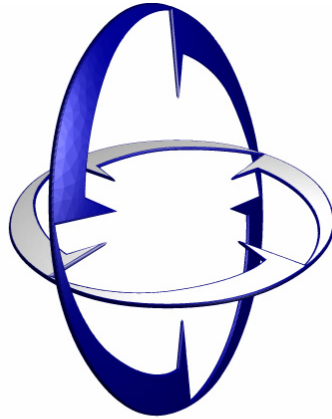

# MEMSENSE

## Wireless IMU Product Specification User Guide

Document Number: PSD-0821  
Document Revision - J



[www.memsense.com](http://www.memsense.com)

888.668.8743



Information provided in this document is believed to be accurate, however it is not guaranteed. MEMSense LLC reserves the right to change product specifications at anytime without notice.

Document Number:

**PSD-0821**

Document Revision:

**J**

Product Number:

**MP00021**

## Wireless IMU Product Specification User Guide

Document Number:

**PSD-0821**

Release / Revision

**J**

Release / Revision Date:

**June 14, 2011**

Document Owner:

**Design Engineering**

## Document Change History

---

Rev	Status	Description	Date
A	Obsolete	New Document	4/24/2008
B	Obsolete	Changed to new MEMSense document format	5/16/2008
C	Obsolete	Updated formatting, updated available accessories in Appendix A5.4	6/20/2008
D	Obsolete	Converted to revision B template along with various document corrections and updates.	12/12/2008
E	Obsolete	Changed Storage Temp on Spec Table from +80 to+60	2/17/2009
F	Obsolete	Changed name to Wireless IMU – updated doc. Removed template change table.	10/8/2009
G	Obsolete	Changed product image on cover page. Changed byte 9 from Prod ID to Reserved. Updated Table 4 and Specifications to include 10G accel. Edited text to remove improper punctuation.	1/28/2010
H	Obsolete	Added information on possible Bluetooth interference.	3/29/2010
J	Released	Fixed error in 5g and 10g accel digital sensitivity. Fixed temperature sensitivity in example formula.	5/14/2011

## TABLE OF CONTENTS

---

- 1.0 INTRODUCTION ..... 1
- 2.0 COMMUNICATIONS ..... 2
  - 2.1 Sample Format ..... 2
  - 2.2 Sample Timer ..... 3
  - 2.3 Data Latency ..... 3
  - 2.4 Measurements ..... 4
  - 2.5 Bluetooth Communications ..... 5
- 3.0 LED INDICATION ..... 5
- 4.0 MECHANICAL ..... 5
  - 4.1 Dimensions ..... 5
  - 4.2 Coordinate System ..... 7
- 5.0 ELECTRICAL SPECIFICATIONS AND OPTIONS ..... 8
  - 5.1 Part Numbering ..... 8
  - 5.2 Specifications ..... 9
  - 5.3 Custom Order Options ..... 10
  - 5.4 Available Bluetooth Accessories ..... 10
  - 5.5 Battery Recommendations ..... 10
- 6.0 TERMS, CONDITIONS AND WARRANTY ..... 11

## 1.0 Introduction

The Wireless IMU series of products provide wireless serial digital outputs of 3D acceleration, 3D angular rate of rotation and 3D magnetic field. Custom algorithms provide temperature, alignment and cross-sensitivity compensation.

With the Bluetooth capability, the IMU can communicate with a wide variety of hosts, from standard PCs, to handheld PDAs, to embedded systems. The range of transmission can be affected by the environment, but typical range capabilities are on the order of 100 feet. Multiple Wireless IMUs can be implemented simultaneously using a LINKSYS USBBT100 Bluetooth USB adapter provided in the Wireless IMU development kit. Data latency may be exhibited as multiple devices are added.

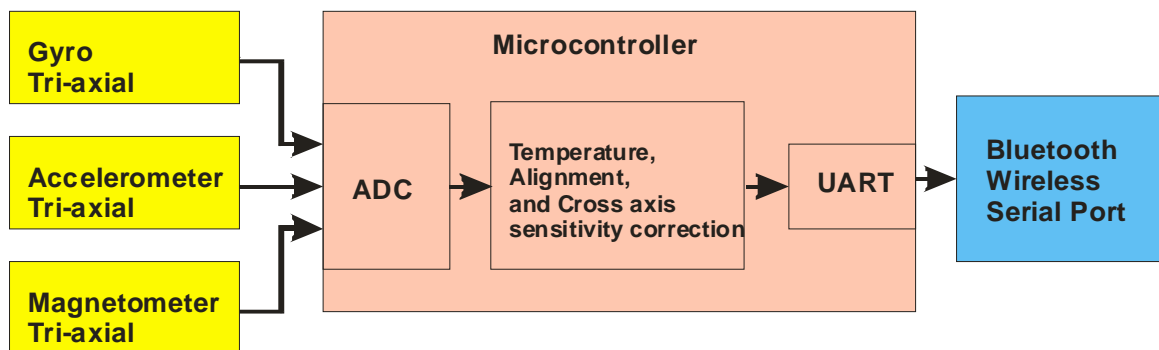

**Figure 1 - Wireless IMU Functional Block Diagram**

### Available options include:

- 1) 2g and 5g acceleration, (see Section 5.1 for part numbering specifications).
- 2) 300, 600 and 1200 °/s rate of rotation with custom configurations available.
- 3) 50 Hz sensor bandwidth with other configurations available.
- 4) 150 Hz sample rate with other configurations available.

## 2.0 Communications

### 2.1 Sample Format

An individual data packet is collectively referred to as a *sample*. Data samples are formatted as shown in Table 1, Sample byte order format. Each data channel (i.e. accelerometer, magnetometer, gyro) is represented by a signed 2's complement, 2-byte short (16-bit) integer that represents the output level of the signal. To convert this value to its corresponding engineering unit see Section 2.4.

**Table 1 - Sample Byte Order Format**

BYTE	ELEMENT	BYTE	ELEMENT
0	Synchronization byte (FF)	19	Accelerometer X (MSB)
1	Synchronization byte (FF)	20	Accelerometer X (LSB)
2	Synchronization byte (FF)	21	Accelerometer Y (MSB)
3	Synchronization byte (FF)	22	Accelerometer Y (LSB)
4	Message size (bytes)	23	Accelerometer Z (MSB)
5	Reserved	24	Accelerometer Z (LSB)
6	Message ID	25	Magnetometer X (MSB)
7	Sample Timer (MSB)	26	Magnetometer X (LSB)
8	Sample Timer (LSB)	27	Magnetometer Y (MSB)
9	Reserved	28	Magnetometer Y (LSB)
10	Reserved	29	Magnetometer Z (MSB)
11	Serial Number MSB	30	Magnetometer Z (LSB)
12	Serial Number LSB	31	Temperature (MSB)
13	Gyro X (MSB)	32	Temperature (LSB)
14	Gyro X (LSB)	33	Reserved
15	Gyro Y (MSB)	34	Reserved
16	Gyro Y (LSB)	35	Reserved
17	Gyro Z (MSB)	36	Reserved
18	Gyro Z (LSB)	37	8-bit Checksum

All samples begin with four (4) synchronization bytes, where each byte contains 0xFF. Synchronization bytes flag the beginning of samples as they arrive from the device. The details on the structure of a sample are as follows (*Note: all byte offsets are zero (0) based*):

- 1.Synchronization bytes: bytes 0-3 with each byte encoded as 0xFF hex.
- 2.Message size: in bytes, of entire data packet, including complete header.
- 3.Message ID: type of message. Currently, only data messages are transmitted by the device with MID = 0x14 hex (20 decimal).
- 4.Sample Timer: Bytes 7 (MSB) and 8 (LSB) when combined represent a 16-bit timer of value of the time at which the ADC started the conversion for the X Gyro with a scale of  $3.0518 \times 10^{-5}$  seconds / count.
- 5.Product Family: 3 for Wireless IMU.
- 6.Serial Number: Unique device identification.

7. Payload: starts at byte 13. The payload size can be calculated as follows:

a. payload size = message size – 13(header) – 1(Checksum byte)

8. Checksum byte: 8-bit checksum byte.

a. Sum sample contents (header + payload). DO NOT include the checksum byte.

b. The summed value should equal the checksum if the message is valid.

c. Note: If greater precision (larger than 8-bit) addition is used to calculate the checksum, the checksum will be the remainder of a divide by 256.

## 2.2 Sample Timer

The Wireless IMU uses an embedded processor to collect and transmit the data. The embedded processor's sample rate of 150Hz is based on an internal oscillator that is specified at +/- 3%. To get a more accurate time measurement, an external oscillator (32.768 KHz, Frequency Tolerance  $\pm$  20 ppm max) drives a counter in the processor. Within the sample packet, bytes 7 (MSB) and 8 (LSB), combined together, represent a 16-bit value of the time difference between samples. The time difference between samples should be on the order of:

$$32.768 \text{ KHz} / 150\text{Hz} = 218 \text{ counts}$$

Timer values will typically show a difference in the range of 215 to 222 except at counter rollover where the difference will be in the range of -65311 to -65318. The sample timer can be used to detect lost packets or packets that got lost in transmission. In situations where a packet was lost, the timer difference will be a close multiple of 218.

To determine the time, in seconds, between samples, first use the timer to calculate the delta, in counts (e.g. delta = sample2 timer – sample1 timer). This delta in counts may then be multiplied by  $3.0518 \times 10^{-5}$  seconds / count to determine the number of seconds between samples.

## 2.3 Data Latency

The sample data is acquired through a series of ten analog to digital conversions. The time from the start of the first conversion to the end of the last conversion is typically 70us. The data is then processed in a compensation algorithm which takes typically 1.04ms. Following the data processing, the packet is transmitted to the host which takes 2.95ms typically or 3.09ms max. Data latency may be exhibited as additional devices are added.

## 2.4 Measurements

The accelerometer, gyro, and magnetometer values may be converted to rotational rate, G-force, and gauss respectively. The data is transmitted as signed (2's complement) 16-bit integers. The following function must be used for conversion of raw values:

**Equation 1:**  $result = raw\_payload \times digital\ sensitivity...$

where the result is the converted value in the appropriate units (e.g. °/s), “raw value” is the raw component-specific value from the payload (e.g. accelerometer X), and “digital sensitivity” is the digital sensitivity of the component (e.g. magnetometer digital sensitivity is  $8.6975 \times 10^{-5}$  from the data sheet on pg. 9). Candidate ranges are as shown in Table 2, Sensor Dynamic Ranges. (NOTE: You must use the digital sensitivities specific to the device you have purchased). For example, if you have purchased a ±300 deg/s, ±2 G Wireless IMU, the corresponding equations for the X component would be:

$$gyro\ value\_x = raw\ payload\_value \times 0.013733$$

$$accelerometer\ value\_x = raw\_payload\_value \times 0.000091$$

where the “raw payload value” is taken from the sample payload corresponding to the x- components of the gyro and accelerometer, respectively. The resulting values have units of degrees/sec and G’s, respectively.

**Table 2 - Sensor component units**

Component	Resulting Units
Gyro	°/s
Accelerometer	G (9.8 m/s <sup>2</sup> )
Magnetometer	Gauss

Although the sensor data is temperature compensated, a customer’s application may require the use of temperature information, therefore a temperature value is provided. The temperature data provided requires a different conversion process. The data is transmitted as signed (2's complement) 16-bit integers. The following function must be used for conversion of temperature sample values:

**Equation 2:**  $result\_deg\_C = raw\_payload\_value \times 1.8165 \times 10^{-2} + 25$

where the result is the converted value in degrees Celsius and “raw value” is the raw value from the payload.

## 2.5 Bluetooth Communications

The Wireless IMU incorporates a wireless serial port module with a unique Bluetooth address. The address can be found by a host system thru a discovery. Pairing with the Wireless IMU is not required, however if desired, the passkey(PIN) is '1111'.

The serial port settings are shown in Table 3 Serial Port Settings. The Wireless IMU uses flow control (i.e. CTS, RTS). The Wireless IMU starts sending sample packets once a Bluetooth connection has been established with a host.

Interference from other devices which use the same frequency range (2.4GHz) as Bluetooth such as 802.11 wireless networks can cause occasional packet loss. This includes using multiple Wireless IMUs at the same time. Other potential interference sources include "noisy" devices such as microwaves and fluorescent lights. The Wireless IMU will attempt to resend any corrupted data, however if it is not able to resend before the next packet is ready to be sent, packets may be lost.

**Table 3 - Serial port settings**

Bits per second	115200
Data bits	8
Parity	None
Stop bits	1
Flow Control	Yes

## 3.0 LED Indication

The red LED on the IMU will indicate when the device is powered-on and when the Bluetooth connection has been established. When the IMU is powered-on and is **not** connected, the LED will blink slowly at a rate of approximately every 3.6 seconds. When a connection has been established, the blink cycle rate will increase to approximately once every second.

## 4.0 Mechanical

### 4.1 Dimensions

The Wireless IMU has four evenly spaced mounting holes that allow for the use of 4- 40, Socket Head Cap Screws. Two evenly spaced holes near the middle provide for alignment pins - 3/32" dowel pin. See Figure 2 and Figure 3 on next page.

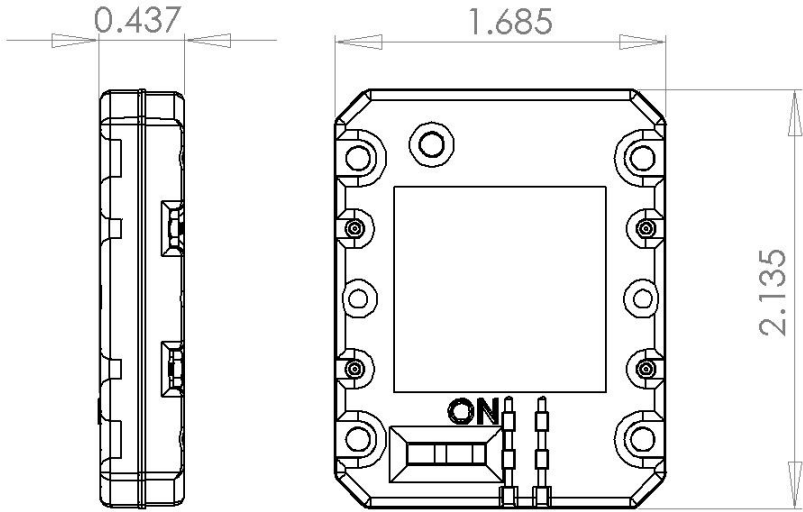

**Figure 2 - Physical dimensions (inches)**

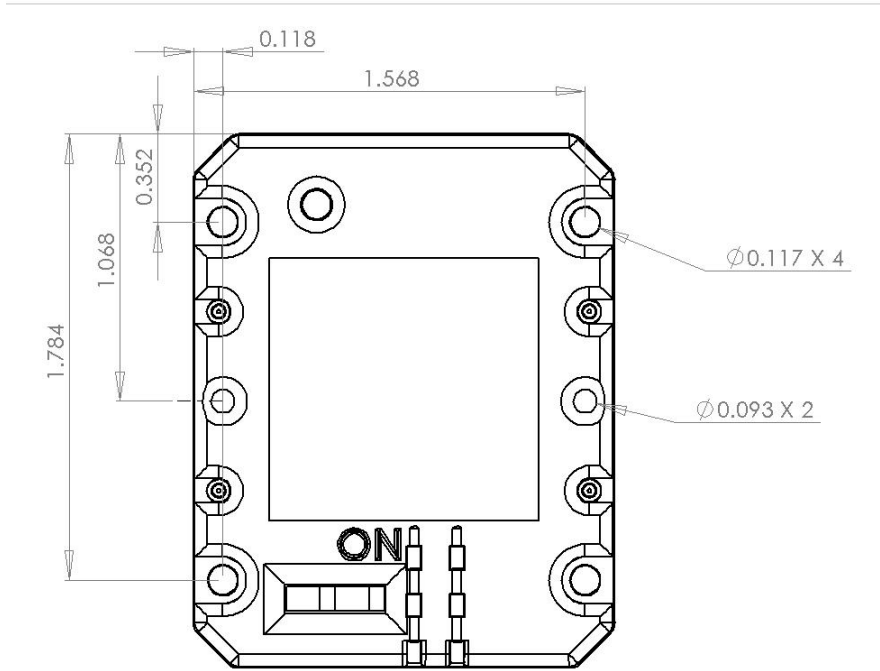

**Figure 3 - Hole pattern dimensions (inches)**

## 4.2 Coordinate System

The coordinate system for the Wireless IMU follows the right hand rule convention. The sign convention for the accelerometers is configured to produce a positive signal when the Wireless IMU is accelerated in the opposite direction of the axis. As an example, with the Wireless IMU pictured in Figure 4 Wireless IMU Coordinate System, if the Z axis is pointed straight down towards the earth, it will produce 0 g for the X and Y axes and a positive 1 g for the Z-axis. A counterclockwise rotation of the IMU about any of the depicted axis will produce a positive angular rate output for the corresponding axis.

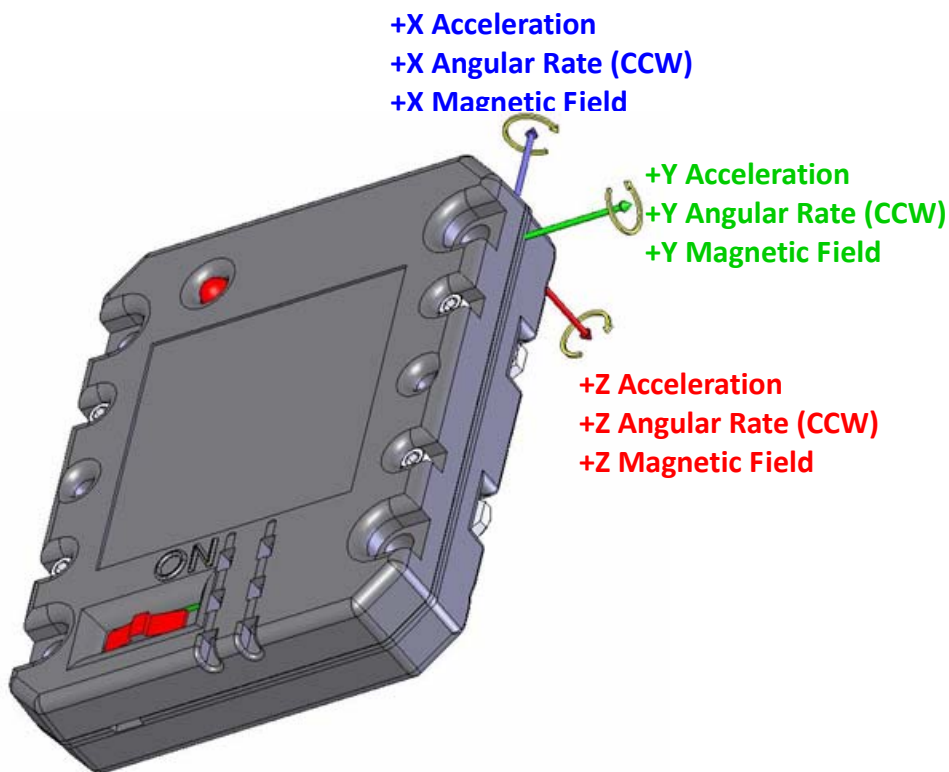

**Figure 4 - Wireless IMU coordinate system**

## 5.0 Electrical Specifications and Options

### 5.1 Part Numbering

BT GG – RRRR F BBB

oGG = Maximum Acceleration in g

oRRRR = max angular rate in °/ second (custom angular rate configurations are available.)

oBBB = Bandwidth in Hz (50 Hz Standard. Other bandwidth configurations are variable).

Table 4 – Standard part numbers

Part	Accel. (g)	Rate (°/s)
BT02-0300F050	2	300
BT05-0300F050	5	300
BT05-0600F050	5	600
BT10-0600F050	10	600

## 5.2 Specifications

PARAMETER	SPECIFICATION			UNITS	CONDITIONS	
<b>Operational Requirements</b>						
Operating Input Voltage	6.0 to 9.0			VDC	Typical	
Supply Current	100			mA		
<b>Physical Properties</b>						
Alignment Error	±1			%		
Mass	23			grams		
<b>Acceleration</b>						
	<b>BT02</b>	<b>BT05</b>	<b>BT10</b>			
Dynamic Range	± 2	± 5	± 10	g	Maximum	
Offset	±30	± 30	± 30	mg		
Nonlinearity	± 0.4 (± 1.0 )	± 0.4 (± 1.0 )	± 0.4 (± 1.0 )	% of FS	Typical (Maximum), 1σ	
Noise	0.72 (1.62)	1.16 (2.29)	2.1 (2.8)	mg	Typical (Maximum)	
Digital Sensitivity	9.1553 x10 <sup>-5</sup>	2.2888 x10 <sup>-4</sup>	4.5776 x10 <sup>-4</sup>	g/bit		
Bandwidth	50	50	50	Hz	-3dB point, Note 1	
<b>Angular Rate</b>						
	<b>-0300F050</b>		<b>-0600F050</b>			
Dynamic Range	± 300		± 600		°/s	Maximum
Offset	+/-1.5		+/-1.5		°/s	
Cross-Axis Sensitivity	1		1		%	Maximum
Nonlinearity	0.1		0.1		% of FS	Best fit straight line
Noise	0.52 (0.98)		0.65(1.26)		°/s	Typical (Maximum), 1σ
Digital Sensitivity	0.013733		0.027465		°/s/bit	
Bandwidth	50		50		Hz	-3dB point, Note 1
<b>Magnetic Field</b>						
Dynamic Range	±1.25			gauss	Maximum	
Offset	+/- .020			gauss		
Cross-Axis Sensitivity	3			%	Maximum	
Nonlinearity	0.5			% of FS	Best fit straight line	
Noise	0.001 (0.002)			gauss	Typical (Maximum), 1σ	
Digital Sensitivity	8.6975x10 <sup>-5</sup>			gauss/bit		
Bandwidth	50			Hz	-3dB point, Note 1	
<b>Range</b>	30			m	Clear line of sight	
<b>Temperature</b>	1.8165 x10 <sup>-2</sup>			°C/bit		
<b>Absolute Max Ratings</b>						
Acceleration Powered	2000 max			g	Any axis 0.5ms	
Input Voltage	-0.3 (min) +9 (max)			VDC		
Operating Temperature	0 to +60			°C		
Storage Temperature	-40 to +60			°C		
Typical Values at 25°C, V <sub>supply</sub> = 7.2 VDC, 0 °/s, unless otherwise noted						

## 5.3 Custom Order Options

- Other bandwidth configurations are available.
- Custom angular rate configurations are available.

## 5.4 Available Bluetooth Accessories

A Linksys USBBT 100 Bluetooth USB Adapter (MP00028) is available for purchase upon request.

MEMSense Part Number	Description
MP00028	Linksys USBBT100 Bluetooth USB Adapter

## 5.5 Battery Recommendations

The following link provides a rechargeable lithium ion battery that is rated at 400mAh which will allow for approximately 4 hours of run time with the Wireless IMU

[9 volt Lithium Ion battery and charger](#)

The next link provides a comparison of non-rechargeable 9 volt batteries. Depending on the manufacturer, the run time can vary from 3 to just under 5 hours.

[9 Volt Battery Comparison](#)

## 6.0 Terms, Conditions and Warranty

**DEFINITION** : As used herein: “Seller” means MEMSense, 2693D Commerce Road, Rapid City, SD 57702. “Buyer” means the party purchasing Product(s) from the Seller. “Product” means all articles, materials, work or services offered by the Seller and described in the accompanying quotation, acknowledgement, invoice, or other Seller form. “Order” means any purchase Order or contract issued by the Buyer for Products provided by the Seller.

**WARRANTY** : Seller warrants that the Products will be free from defects in material and workmanship and conform in all material respects to their applicable specifications for a period of one (1) year from the date of delivery (“Warranty Period”), when operated under normal conditions and in accordance with their applicable specifications. For any breach of this warranty, Seller will, at its option and expense and as its sole obligation, and as Buyer’s exclusive remedy, repair or replace any defective Product returned to Seller during the Warranty Period, provided that an examination by Seller discloses to Seller’s reasonable satisfaction that a defect is covered by this warranty. This warranty does not apply to any Products that have been (i) subject to misuse, neglect, or abuse, (ii) improperly installed or maintained, or (iii) repaired or altered by anyone other than Seller. The warranty period for Products repaired or replaced under this warranty shall be limited to the components repaired or replaced and shall run for a period of one hundred and eighty (180) days from the date of delivery or the balance of the original one (1) year Warranty Period (excluding the time the Products were out of service and in Seller’s plant), whichever is longer. EXCEPT AS STATED IN THIS SECTION, SELLER MAKES NO WARRANTIES, EXPRESS OR IMPLIED, AND SPECIFICALLY DISCLAIMS ANY IMPLIED WARRANTIES OF FITNESS FOR A PARTICULAR PURPOSE, MERCHANTABILITY, TITLE, AND NON-INFRINGEMENT OF THIRD PARTY RIGHTS.

**LIMITATION OF LIABILITIES** - In no event shall Seller be liable to Buyer or any third party for consequential, indirect, punitive, special, or incidental damages (including but not limited to loss of profits) arising from or relating to the sale, delivery or use of the Products. Seller’s total cumulative liability under this Agreement to Buyer or any third party (including indemnity obligations), whether in contract or tort or otherwise, will not exceed the amount paid by Buyer to Seller for the Product sold hereunder giving rise to such liability.

**DELAYS** - Seller shall not be liable for delay in delivery or for failure to manufacture, due to causes beyond its reasonable control, including but not limited to acts of God, acts of any government, acts of civil or military authority, acts of Buyer, application of US Government priorities, Government delays in granting Export Licenses, fires, strikes, floods, war, terrorism, riot or civil commotion, delays in transportation, difficulty in obtaining necessary labor or materials. In the event of any such delay, date of delivery shall be extended for a period of time equal to that lost by reason of the delay.

**TAXES** - Prices do not include sales or excise tax, VAT, duties or other governmental charges resulting from this transaction or the manufacture, sale, ownership, possession, or use of the Products, all of which must be paid by Buyer. Buyer shall provide Seller a tax exemption certificate acceptable to the taxing authorities.

**SHIPMENT** - Title to all purchased material and risk of loss therefore is passed from Seller to Buyer at the time of shipment from Seller’s facility. Unless otherwise agreed upon in writing, all purchased material will be shipped uninsured. Seller may request partial shipment and invoice therefore.

**EXPORT LICENSE** – Buyer will comply with all applicable export and import control laws and regulations in its use of the Products and Buyer will not export or re-export the Products or any technical data or confidential information derived from or pertaining to the Products without all required United States and foreign government licenses.